

CONCEPT PLAN 10
MIDBLOCK SPEED TREATMENT
OPTIONS

● *These options are under consideration in Macnamara Avenue and Patterson Street*

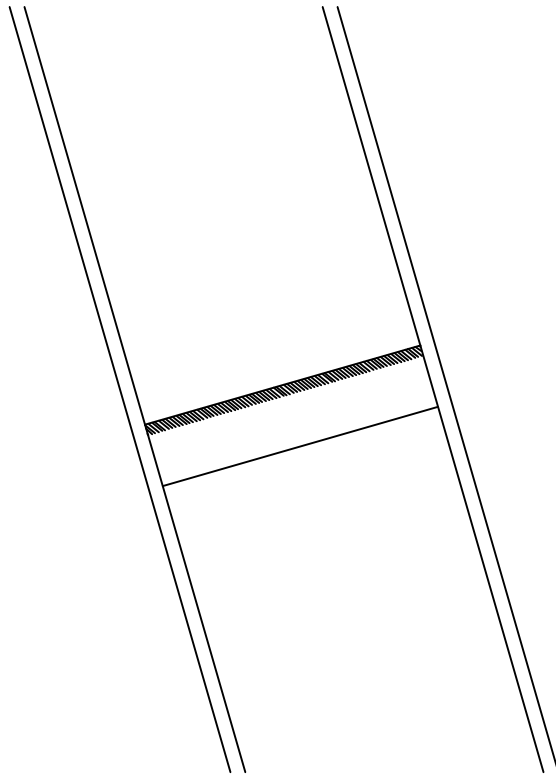

(a) Bitumen Speed Hump

- *Retains parking*
- *Effective speed control*
- *Noise impact on nearby residents*

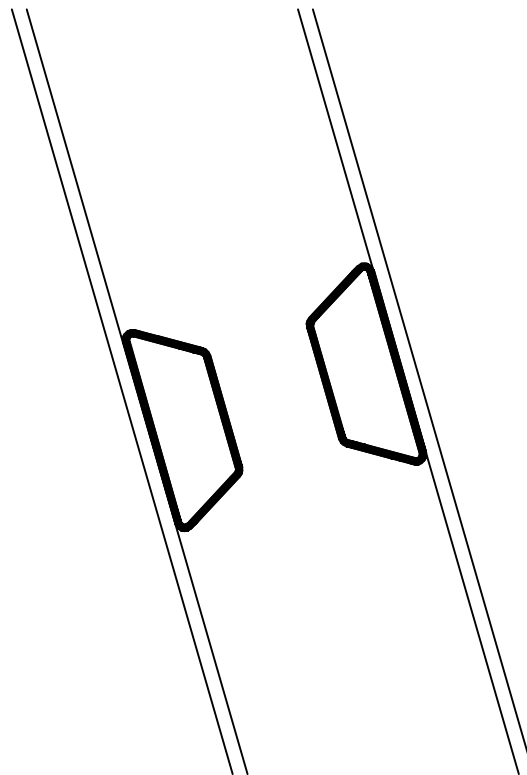

(b) One Lane Narrowing

- *No noise impact*
- *Loss of parking*
- *Some motorists may continue to speed*

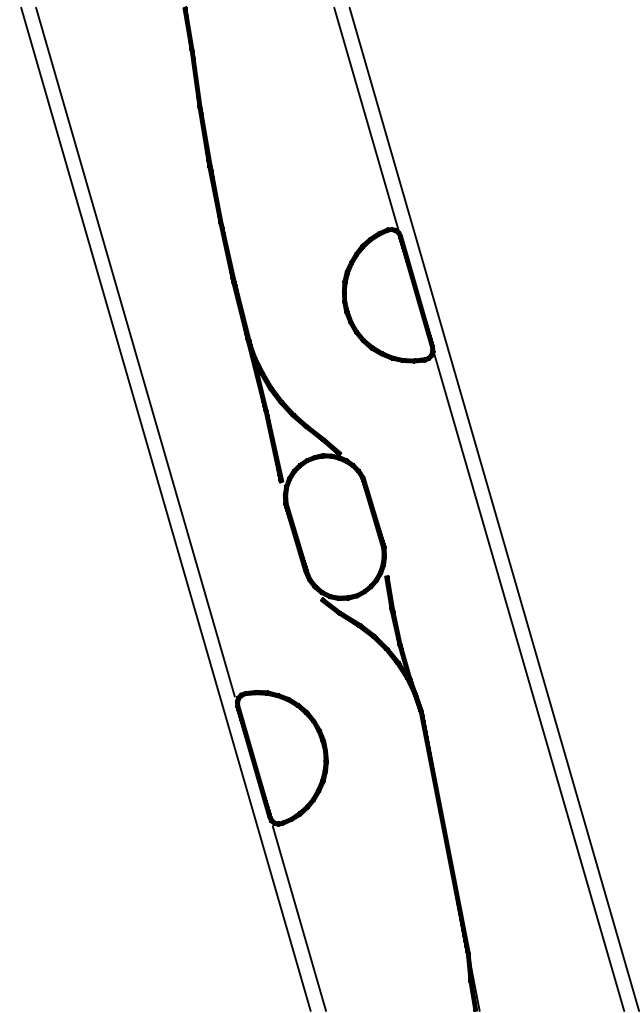

(c) Oval Slow Point

- *Effective speed control*
- *No noise impact*
- *Loss of parking*